

# Waterproof Magnetic Lock

## Specification

Model	Waterproof Magnetic Lock	Waterproof Magnetic Lock with signal
Dimension	230Lx72Wx37.8H(mm)	230Lx72Wx37.8H(mm)
Holding force	500kg(1200Lbs)	500kg(1200Lbs)
Current	DC12V or DC24V	DC12V or DC24V
Voltage	12V/500mA±10% 24V/250mA±10%	12V/500mA±10% 24V/250mA±10%
Signal output	NO	Lock signal NO/COM
Suitable for	Wooden door ; Metal door; Fireproof door	Wooden door ; Metal door; Fireproof door
Operating temp	-20℃~+55℃	-20℃~+55℃
IP rate	IP-68	IP-68
Weight	4.5kg	4.5kg

## Dimension (unit:mm)

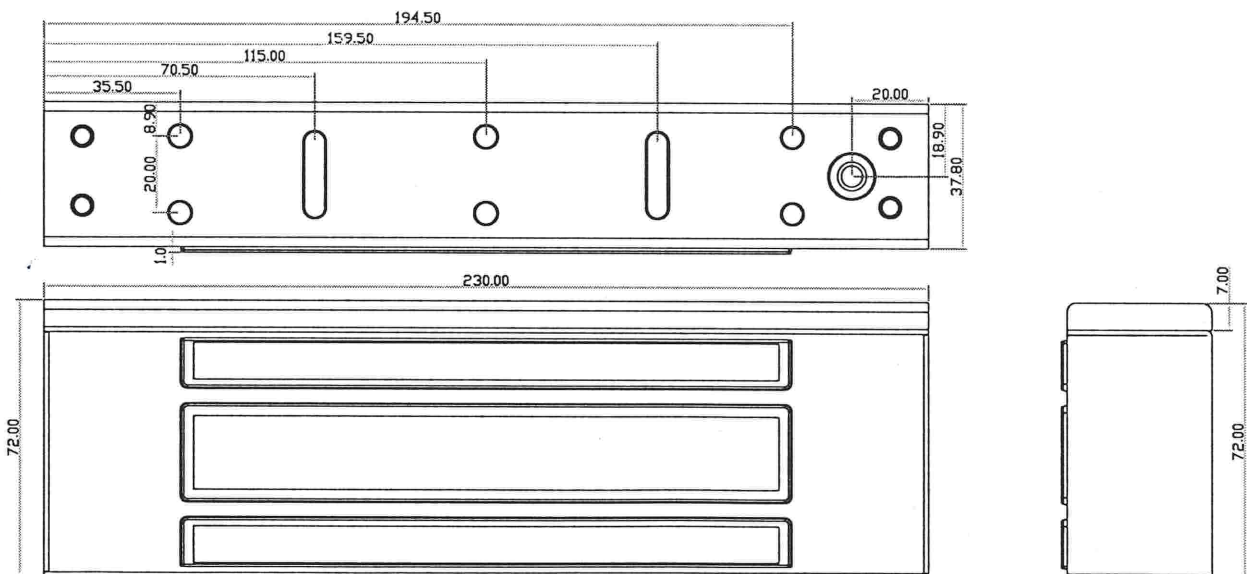

**Notice:** Please read the following instructions before installation.

- Please handle the lock carefully. Any damage of the surface or the armature plate will reduce the magnetic force.
- Fix the lock on the door frame and the armature plate on the door leaf. The accessories can provide better conjunction to the lock and the armature plate.
- Please keep the door closed when you drill holes.
- Fasten the screws of the lock.
- The limit value of the reed switch of the door signal detection is 0.5A/30V DC. Don't overload.
- Make sure the armature plate can be slightly shaken when locked, for the rubber washer need some spaces to adjust the position of the armature plate and the lock.
- Please select the correct wiring for DC 12V or DC 24V voltage input.

## Circuit Board Diagram

### A. 12V DC Input

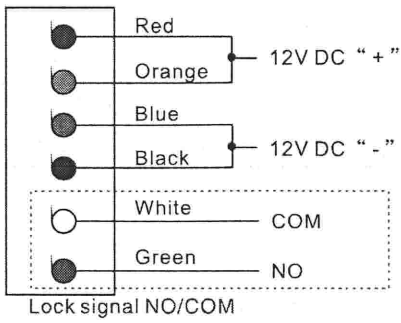

### B. 24V DC Input

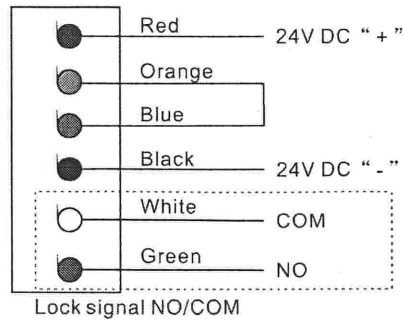

## Installation Instruction

Note: The center of the Armature plate must be installed in the center of the lock cylinder, the unilateral deviation of up and down cannot exceed 3mm. The lock signal will be invalid if maximum offset value is exceeded.

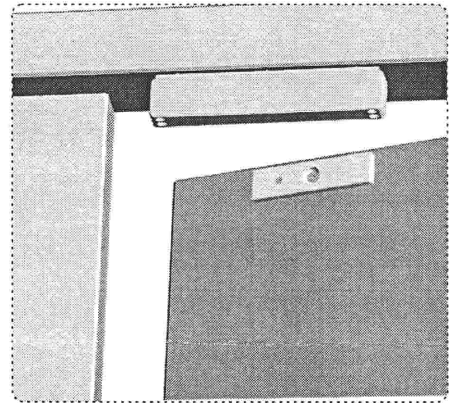
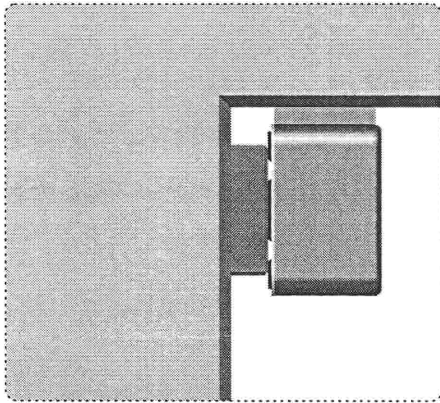

## Wire Connection

