

The JA-162PW/JA-162PW (G) Wireless dual PIR & MW motion detector

This product is a wireless component of the **JABLOTRON 100+** system. It is designed to detect human body movement inside buildings. High immunity to false alarms is reached thanks to the combination of PIR and microwave (MW) detection. The detector works like a classic PIR detector, however when PIR detects movement in a guarded area, the MW part is activated and confirms the previous PIR activation. Only then an alarm is triggered and is sent to the control panel. The JA-162PW features a white lens that provides standard white light immunity as defined by the norm (up to 6000 lux). The JA-162PW (G) detector features a grey lens that provides increased white light immunity, way above the requirements defined by the norm (up to 10000 lux). This lens helps to reduce false indication of alarms caused by example: car headlight refraction, the setting sun, lightning or reflective surfaces. The immunity to false alarms can be set at two levels, PIR and MW. The detector operates with pulse reaction (indicates only its activation) and takes up a single position in the system. This detector is intended to be installed by a trained technician with a valid certificate issued by an authorised distributor. **This device is compatible only with the JA-103K, JA-107K and newer control panels.**

Installation

Given the principle and detection characteristics of the MW detector, the best results can be achieved when the detector is installed in a corner of a room. No moving objects (e.g. waving curtains above a radiator) or animals should be in the detector's field of vision. There should be no obstacles in front of the detector which could obstruct its view and it should not be installed near metal objects (they could affect the MW field). It is also not possible to install two and more detectors in an area where MW transmitters could affect each other.

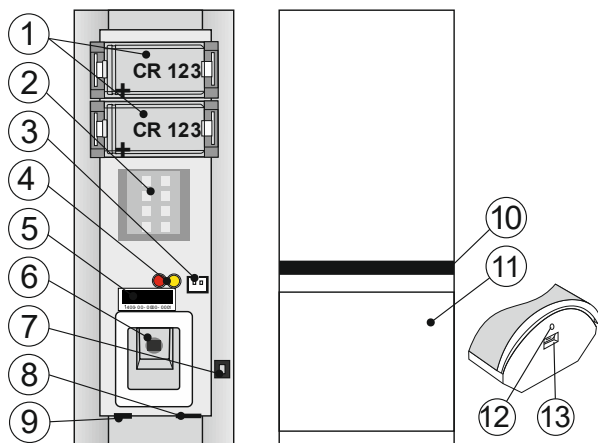

Fig 1: 1 – battery holders; 2 – MW sensor; 3 – The JA-191PL external tamper connector; 4 – detector state indicators; 5 – production code; 6 – PIR sensor; 7 – tamper contact; 8 – antenna; 9 – PCB tab; 10 – light guide; 11 – PIR detector lens; 12 – arresting screw hole; 13 – cover tab

1. Open the detector cover by pushing the tab (13). Avoid touching the PIR sensor inside (6) – you could damage it.
2. Take out the PCB – it is held in by tabs (9) at the lower part of the cover.
3. Punch through the holes for screws in the place base. The recommended installation height is 2.5 m above the floor. In order to fully take advantage of device removal tamper detection, it is necessary to utilize the screw hole surrounded by perforation.
4. Put the PCB back and proceed according to the control panel installation manual. Basic procedure:
 - a. The control panel must feature JA-11xR radio module.
 - b. Go to the **F-Link** software, select the required position in the **Devices** window and launch the **Enrollment mode** by clicking on the **Enroll** option.
 - c. By inserting the first battery a (1) yellow LED will start to flash, only after the inserting the second battery an enrollment signal will be transmitted and the detector enrolled onto a selected position. **Mind the correct polarity when inserting the batteries.**
 - d. This is followed by a detector stabilization phase (which may take up to three minutes), that is indicated by a (4) red glowing light.
5. Close the detector cover. In order to be fully compliant with regulations, it is necessary to fix the cover in place with the use of an arresting screw (12).
6. Settings can be adjusted by following the *Detector internal settings* chapter.

Notes:

- The detector can also be enrolled into the system by entering its production code in the **F-Link** program. The serial number is on a label with a bar code which is placed inside the detector (5). All numbers shall be entered (example: 1400-00-0000-0001).
- If you want to remove the detector from the system, delete it from its position in the control panel.

Detector internal settings

The detector properties can be set in the **Devices** tab of the **F-Link** software. Use the **Internal settings** button, on the same position as the detector, to open a dialog window where you can set following (factory settings are marked with *).

PIR immunity level: determines a level of immunity to false alarms. **Standard*** combines basic immunity with a fast sensor reaction. **Increased** has stronger immunity with a slower reaction time.

MW immunity level: determines the level of analysis performed by the MW motion detector. **Standard*** combines basic immunity with a fast sensor reaction. **Increased** has stronger immunity and provides a slower reaction time.

MW sensitivity: 100%, 75%, 50%, 25%. In some instances the microwave detection is capable of detecting movement behind solid obstacles – such as walls, glass panels, drywall, etc. It is recommended to perform a test in the test mode – MW and in case of any unwanted triggers, gradually decrease the sensitivity.

MW activation: Any set* / Complete / Always / Never. By default PIR activation confirmed by MW detector is turned on both in partial and complete situation when system is set. In an unset state the MW detection is turned off (therefore the detector is activated in an unarmed state by the PIR sensor). By changing the setting to **Complete**, MW detection is active only if a section is fully set. MW detection is disabled if a section is partially set or in an unset state. If the third setting is chosen, the MW detector is always activated, even in an unarmed set state. **(Please note, this setting can drastically impact detector battery life expectancy, depending on the number of activations).** Confirmation by MW detection can be completely turned off by choosing the **Never** option, in which case the detector behaves like a standard PIR detector.

Sensor of tearing-off from the wall: turns off/on the detection on the additional tamper sensor featured on the JA-191PL PIR jointed bracket.

Test mode: The PIR+MW and MW buttons are intended to be used for detector testing. In order to initialize the test mode, the control panel must be in service mode. By pressing the PIR+MW button, the detection test mode of regular operation is initiated. By pressing the MW button, the MW detection test mode is initiated, which allows for a thorough control of detection sensitivity in order to prevent the possibility of initiating a false alarm. In both modes, detection is indicated by the flash of a red LED light, at the same time a signal is transmitted onto the control panel – which can be seen on the **Diagnostics** tab within **F-Link**. The test mode is exited either by pressing the PIR+MW button or leaving the internal settings tab.

Battery replacement

The system sends automatic reports when the battery is low. We recommend changing the batteries within two weeks since a low battery status has been indicated. Battery replacement is done by a technician with the control panel in service mode, or by an authorized user in the maintenance mode.

It is necessary to wait for 10 seconds before inserting new batteries, or triggering the (7) cover tamper switch and thus discharging remaining charge from within the detector.

Notes:

- Insertion of empty batteries is immediately indicated by the detector by flashing the red LED for the duration of detector stabilisation (15 seconds).
- Battery status can be seen in the **F-Link** program, within the **Diagnostics** tab.
- In order to ensure proper detector function, we recommend the use of batteries supplied by the Jablotron distribution network. (BAT-3V0-CR123A) or other high-quality namebrand lithium batteries.
- Please do not discard used batteries into trash, instead take them to a designated collection bin.

The JA-162PW/JA-162PW (G) Wireless dual PIR & MW motion detector

Detector Testing

If the control panel is in service mode, every movement registered by the detector is indicated by an LED. By exiting the service mode, the control panel will enter the operational mode, which is set within the internal settings. Individual detector activations can be seen within the **F-Link** program under the **Diagnostics** tab.

In operational mode, the LED indication function is completely disabled, even the yellow LED – which indicated failure.

The **PIR sensor** is equipped with a 90°/12 m lens. Coverage see - Fig 2.

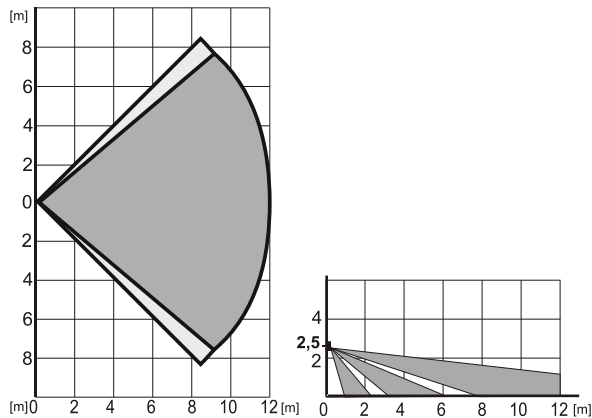

Fig 2: detection characteristic.

MW sensor reacts to movement within the range of 0 m to 12 m – grey characteristic. MW sensor can in certain instances detect movement behind non-metallic solid objects, (such as: walls, doors, glass, etc.). Due to the nature of MW detection, the detection characteristic can drastically change in relation to size, shape and furnishing of a protected area, especially with regard to metallic materials which can reflect or overshadow transmitted MW signal.



During installation, it's always necessary to test whether the detector sufficiently covers the area.

Installation accessories

JA-196PL-L – Detector wall holder.

If a more aesthetic installation is required, it is possible to use the JA-196PL-L wall bracket, it is supplied in two colors – white and grey. With the use of this bracket it is possible to partially set the detector within a wall or drywall.

JA-191PL – PIR jointed bracket.

It is used for special placement, such as installation on the ceiling or at a tilted angle (greater installation height). The jointed bracket is a certified detector accessory having its own tamper contact which is to be connected inside the detector (3).

Technical specifications

Power supply:	2x lithium battery, type: CR123A (3 V/1500 mAh) Please note: Batteries are not included.
Typical lifetime of batteries:	4 Years
LowBatt state:	< 2,7 V
Quiescent current consumption:	65 µA
Maximální odběr proudu:	50 mA
Communication band:	868,1 MHz, JABLOTRON protocol
Maximum radio-frequency power (ERP):	25 mW
Communication range:	cca 300 m (open area)
Recommended installation height:	2,2 – 2,5 m nad úrovní podlahy
Detection angle / detection coverage PIR:	90°/12 m
Detection angle / detection coverage MW:	80°/12 m
Operational frequency MW:	24,125 GHz
Maximum radio-frequency power (ERP):	30 mW
Dimensions:	63 x 150 x 40 mm
Weight (w/o batteries):	125 g
Classification	Security grade 2/Environmental class II (according to EN 50131-1)
Operating temperature range	-10 °C to +40 °C
Average operating humidity	75 % RH, w/o condensation
Certification body	Trezor Test s.r.o. (no. 3025)
In compliance with	ETSI EN 300 220-1,-2, ETSI EN 300 440, EN 50130-4, EN 55032, EN 62368-1, EN 50581, EN 50131-1, EN 50131-2-4, EN 50131-5-3, EN 50131-6
Operating conditions according to general authorization	ERC REC 70-03



JABLOTRON ALARMS a.s. hereby declares that the JA-162PW/JA-162PW (G) product is in compliance with the relevant Union harmonisation legislation: Directives No: 2014/53/EU, 2014/35/EU, 2014/30/EU, 2011/65/EU if it is used as intended. The original of the conformity assessment can be found at www.jablotron.com - Section Downloads.

Note: Although this product does not contain any harmful materials we suggest you return the product to the dealer or directly to the producer after use. For additional info please visit www.jablotron.com in the download section.