

DC101

Opbouwcontact met sabotagelus, 2,5m, wit, schakelafstand ±15mm, NC.

DC101-Series

The DC101-Series surface mount magnetic contacts are designed for use in installations where a small, sealed unit is required. The reed switch is totally encapsulated in an exclusive polyurethane potting compound preventing moisture from entering the switch and causing false alarms.

Easy installation

The 16 mm standard gap distance allows for fast, easy installation and prevents false alarms from loose fitting doors. Recessed mounting holes make for clean-looking installations.

High Quality components and materials

Reed legs are plated with rhodium or ruthenium, and hermetically sealed in dry nitrogen. This offers superior protection against sticking and provides a moisture free environment therefore preventing corrosion.



Details

- Convenient surface mounting
- Standard 2 m wire length
- Tamper loop provided
- Neat and tidy design

DC101

Opbouwcontact met sabotagelus, 2,5m, wit, schakelafstand ± 15 mm, NC.

Technische specificaties

Algemeen

Type toepassing	Oppervlaktemontage
Type contact	NC
Aansluiting	4 wires, 2 m

Bedraad / draadloos

Bedraad / draadloos	Bekabeld
Werkingsafstand	15 mm (max.)

Fysiek

Fysieke afmetingen	51 x 9 x 9 mm
Kleur	Wit

Omgeving

Montagevlak materiaal	Ferrometaal, Non-ferrometaal
-----------------------	------------------------------

Regelgevend

EN50131 Grade	Graad 2
---------------	---------

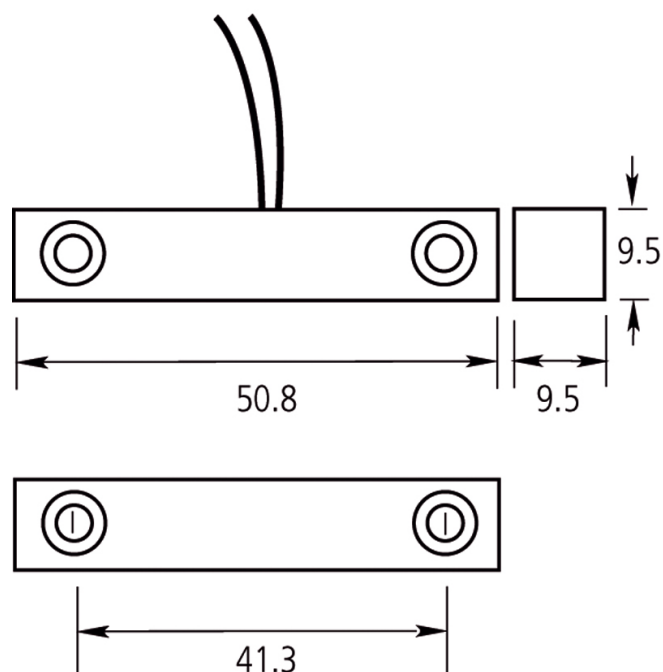

Als een bedrijf van innovatie behoudt Carrier Fire & Security zich het recht voor productspecificaties zonder kennisgeving te wijzigen. Ga voor de nieuwste productspecificaties online naar nl.firesecurityproducts.com of neem contact op met uw verkoopvertegenwoordiger.

Last updated on 5 May 2023 - 9:32